

CONTOURE®

SPACE SAVER APPLIANCES

3 BURNER RV COOKTOP WITH GLASS COVER



INSTRUCTION MANUAL MODEL:

CT-1700 - Stainless Steel

CT-1700BK - Black

Before using your appliance, please read this manual carefully & keep it for future reference. The design and specifications are subject to change without prior notice for product improvement.



Table of Content

Welcome	4
Important Safety & Precautions	5
Installation Instructions.....	10
Operating Instructions.....	21
Care & Maintenance.....	26
Troubleshooting Guide.....	28
Product Registration.....	30
Product Warranty	31

Welcome

Thank you for purchasing a **CONTOURE** 3 Burner RV Cooktop.

Congratulations on your new product. For your safety and full enjoyment of this product, always read the instruction book carefully before using.

Please do not forget to register your product for updates and other relevant product information. To register your product, visit our website **www.contourea.com**

By completing your product registration, you are protecting your new investment and obtaining important warranty service information unique to your product.

This manual contains important information on the installation, use, and care of your appliance. Please read this manual carefully before installation and operation of this machine to prevent injury and property damage and to take full advantage of your new cooktop's benefits and features.

Important Safety Information

READ ALL INSTRUCTIONS BEFORE USING THE APPLIANCE

WARNING

Read all safety instructions before using the product. Failure to follow these instructions may result in fire, electrical shock, serious injury or death.

WARNING

If the information in this manual is not followed exactly, a fire or explosion may result, causing property damage, personal injury or death.

Do not store or use gasoline or other flammable vapors and liquids in the vicinity of this or any other appliance.

WHAT TO DO IF YOU SMELL GAS:

- Do not try to light any appliance.
- Do not touch any electrical switch.
- Do not use any phone in your recreational vehicle.
- Clear the recreational vehicle of all occupants.
- Turn off the gas supply tank valve(s) or main gas supply.
- Immediately call your gas supplier for instructions.
- If you cannot reach your gas supplier, call the fire department.
- Have the gas system checked and leakage source corrected by a qualified installer, service agency, manufacturer, dealer or the gas supplier.

Important Safety Information

GENERAL SAFETY INSTRUCTIONS

WARNING

Carbon Monoxide Poisoning. Never use this appliance as a space heater to heat or warm the room. Doing so may result in Carbon Monoxide poisoning or overheating of the oven. A window or air vent should be open slightly while using this appliance. Gas flames consume oxygen which must be replaced to assure proper combustion.

- Use this appliance for its intended purpose as described in this owner's manual.
- Have your cooktop installed by a qualified installer in accordance with the provided installation instructions.
- Any adjustment and service should be performed only by a qualified gas installer or service technician. Do not attempt to repair or replace any part of your cooktop unless it is specifically recommended in this manual.
- Your cooktop is shipped from the factory set for use with propane gas. It can not be converted to any other gas.

- Have the installer show you the location of the cooktop gas shut-off valve and how to turn it off if necessary.
- Be sure all packing materials are removed from the cooktop before operating to prevent ignition of these materials.
- Do not leave children alone or unattended in an area where an appliance is in use. They should never be allowed to climb, sit or stand on any part of the appliance.

CAUTION

- Do not store items of interest to children in cabinets above an cooktop - children climbing on the cooktop to reach items could be seriously injured.
- Never block the vents (air openings) of the cooktop. They provide the air inlets and outlets that are necessary for the cooktop to operate properly with correct combustion. Air openings are located at the rear, front, and bottom of the cooktop.
- Use only dry pot holders—moist or damp pot holders on hot surfaces may result in burns from steam. Do not let pot holders touch surface burners or burner grates. Do not use a towel or other bulky cloth in place of pot holders.
- Do not heat unopened food containers. Pressure could build up and the container could burst, causing an injury.

- Cook food thoroughly to help protect against foodborne illness. Minimum safe food temperature recommendations can be found at IsItDoneYet.gov and fsis.usda.gov. Use a food thermometer to take food temperatures and check several locations.
- Do not allow anyone to climb, stand or hang on the cooktop. They could damage the cooktop or tip it over causing severe injury or death.

 **WARNING** **KEEP FLAMMABLE MATERIALS AWAY FROM THE COOKTOP**

Failure to do so may result in fire or personal injury.

- Do not store or use flammable materials on a cooktop, including paper, plastic, pot holders, linens, wall coverings, curtains, drapes and gasoline or other flammable vapors and liquids.
- Never wear loose-fitting or hanging garments while using the appliance. These garments may ignite if they contact hot surfaces causing severe burns.
- Do not let cooking grease or other flammable materials accumulate in or near the cooktop. Grease on the cooktop may ignite.

 **WARNING** **IN THE EVENT OF A FIRE, TAKE THE FOLLOWING STEPS TO PREVENT INJURY AND FIRE SPREADING**

Do not use water on grease fires. Never pick up a flaming pan. Turn the controls off. Smother a flaming pan on a surface unit by covering the pan completely with a well-fitting lid, cookie sheet or flat tray. Use a multi-purpose dry chemical or foam-type fire extinguisher.

Important Safety Information



COOKTOP SAFETY INSTRUCTIONS

- Never leave the surface burners unattended. Foods, especially oily foods, may ignite resulting in fire that could spread to surrounding cabinets.
- Never leave oil unattended while frying. If allowed to heat beyond its smoking point, oil may ignite resulting in fire that may spread to surrounding cabinets. Use a deep fat thermometer whenever possible to monitor oil temperature.
- To avoid oil spillover and fire, use the minimum amount of oil when using a shallow pan-frying and avoid cooking frozen foods with excessive amounts of ice.
- Use proper pan size and avoid pans that are unstable or easily tipped. Select cookware that is matched to the size of the burner. Burner flames should be adjusted so that they do not extend beyond the bottom of the pan. Excessive flame may be hazardous.
- Always use the HI position when igniting the top burners and make sure the burners have ignited.
- When using glass/ceramic cookware, make sure it is suitable for cooktop service; others may break because of sudden change in temperature.
- To minimize the possibility of burns, ignition of flammable materials and spillage, the handle of a container should be turned toward the center of the cooktop without extending over nearby burners.
- Do not use a wok. Doing so may trap heat and block air to the burner resulting in a carbon monoxide hazard.
- Do not use aluminum foil to cover the grates or line any part of the cooktop. Doing so may result in carbon monoxide poisoning, overheating of the cooktop surfaces, or a potential fire hazard.
- Raise cover into full open position before operating burners. Let cooktop cool before closing glass cover.



WARNING



FIRE OR EXPLOSION HAZARD

If the information in this manual is not followed exactly, a fire or explosion may result causing property damage, personal injury or death.

Installation must be performed by a qualified installer. Read these instructions completely and carefully.

Installation of this appliance must conform with state and other codes or, in the absence of such codes, with:

In the USA: the Standard for Recreational Vehicles, ANSI/NFPA 1192.

In Canada: CAN/CSA Z-240.4.2-08 Installation Requirements for Propane Appliances and Equipment in Recreational Vehicles.

This range has been design-certified by CSA International according to ANSI Z21.57, latest edition and CAN1-1.16-M79, latest edition.

When installing a gas appliance, the use of old flexible connectors can cause gas leaks and personal injury.

Always use a **NEW** flexible connector.

Leak testing of the appliance shall be conducted according to the manufacturer instructions.

If an external electrical source is utilized, the appliance, when installed, must be electrically grounded in accordance with state or, in the absence of such codes, with the National Electrical Code, ANSI/ NFPA 70.

Do not install this product with an air curtain hood or other range hood that operates by blowing air down on the cooktop. This airflow may interfere with operation of the gas burners resulting in fire or explosion hazard.

PROPER DISPOSAL OF YOUR APPLIANCE

Dispose of or recycle your appliance in accordance with Federal and Local Regulations. Contact your local authorities for the environmentally safe disposal or recycling of your appliance.

Installation Instructions

WARNING

Certain Detection Equipment is Required in Recreation Vehicles per NFPA 1192. Required equipment shall be UL approved for use in recreational vehicles. Install and use equipment in accordance with the manufacturer's instructions.

Smoke Alarm -

Section 6.3.1 identifies that all recreational vehicles shall be equipped with a smoke alarm.

Carbon Monoxide Alarm -

Section 6.3.2 identifies that all recreational vehicles shall be equipped with a Carbon Monoxide alarm.

Propane Detector -

Section 6.3.3 identifies that all recreational vehicles with a propane appliance shall be equipped with a propane detector.

BEFORE YOU BEGIN

IMPORTANT:

Save these instructions for local inspector's use.

IMPORTANT:

Observe all governing codes and ordinances.

IMPORTANT:

Remove all packing material and literature from cooktop before connecting gas and electrical supply to cooktop.

IMPORTANT:

To avoid damage to your cabinets, check with your builder or cabinet supplier to make sure that the materials used will not discolor, delaminate or sustain other damage. This cooktop has been designed in accordance with the requirements of CSA International and complies with the maximum allowable wood cabinet temperatures of 194°F (90°C).

⚠ WARNING ⚡

The cooktop must be completely separated and/or sealed from other air moving or air consuming devices such as but not limited to microwave ovens, furnaces, water heaters, cooling fans, and clothes dryers. Failure to do so will affect the cooktop's combustion air supply by creating either a negative or positive draft.

Note to Installer – Be sure to leave these instructions with consumer.

Note to consumer – Keep these instructions for future reference. Proper installation is the responsibility of the installer. Product failure due to improper installation is not covered under warranty.

MATERIALS YOU WILL NEED

- Pipe joint sealant or UL-approved pipe thread tape with Teflon* that resists action of natural and propane gases
- Liquid leak detector or soapy water.
- Propane supply line with a 3/8" flare female connection

*Teflon: Registered trademark of DuPont

WHAT'S IN THE BOX

Make sure you have all the following items included in the packaging. If any item is damaged or missing, contact your dealer.

- Cooktop x 1
- Cooktop Grate x 1
- #8-15 x 1" wood screw x 4
- Owner's Manual and Installation Instructions x 1

TOOLS YOU WILL NEED



Adjustable Wrench (2)

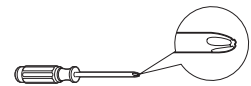

Phillips Screwdriver

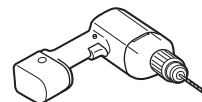

Electric Drill with 1/8" Drill bit



Safety Glasses



Gloves

Installation Instructions

CABINET AND COUNTER CUTOUT DIMENSIONS

Ensure cabinets and countertop meet the requirements from the table before installing the cooktop.

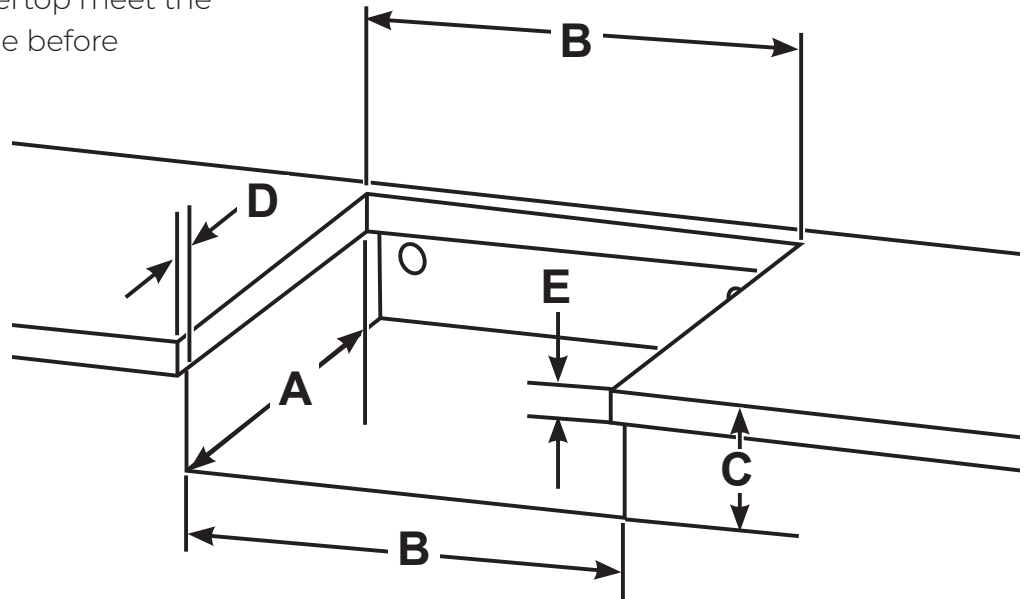

Model	A (depth)	B (width)	C (height)	D (overhang)	E (thickness)
CT1700	17.75"	20.25"	4.125"	1" max	1.625" max

NOTE: There should be an unobstructed vertical gap of .25" underneath the rangetop to allow for proper combustion and cooling airflow. Do not block this gap.

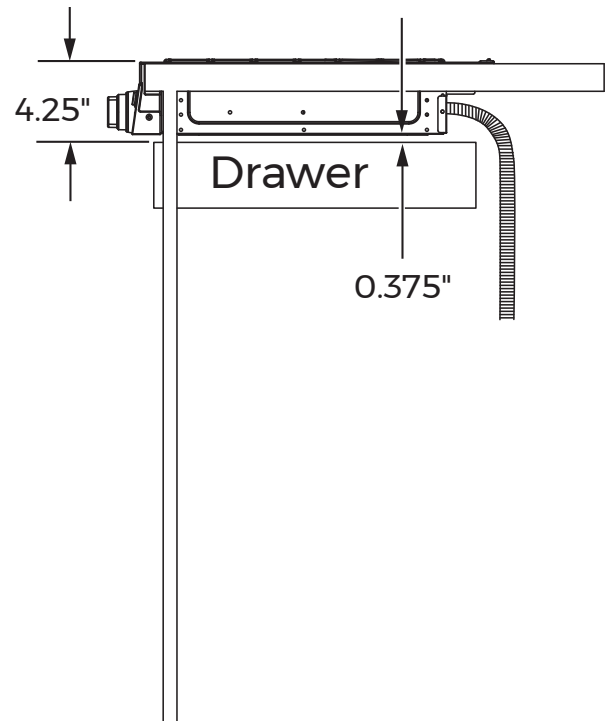

NOTE: Allow .375" minimum vertical clearance from the cooktop bottom (or 4.25" minimum depth from the countertop) to any combustible surfaces, such as a cabinet drawer.

INSTALLATION CLEARANCES

Models	A	B	C	D	E	F
CT1700	30" min.	18" min.	13" max.	2" min.	2" min.	20.25" min.

A: Allow 30" minimum vertical clearance between the countertop and combustible construction above the appliance. For alternative vertical clearances, refer to NFPA 1192 Table 5.6.6.5 for hood requirements.

B: Allow 18" minimum vertical clearance between the countertop and combustible construction to the left and right sides of the appliance.

C: The maximum allowable depth of overhead cabinets is 13". For overhead cabinet depths exceeding 13", refer to NFPA 1192 Table 5.6.6.5 for hood requirements.

D: Allow a minimum of 2" of horizontal clearance between the appliance cutout and combustible construction extending from the cooking surface to 18" above the cooking surface.

E: Allow a minimum of 2" of clearance between adjacent combustible construction and the back of the appliance cutout.

F: The width of Vertical Clearance A shall not be less than 20.25".

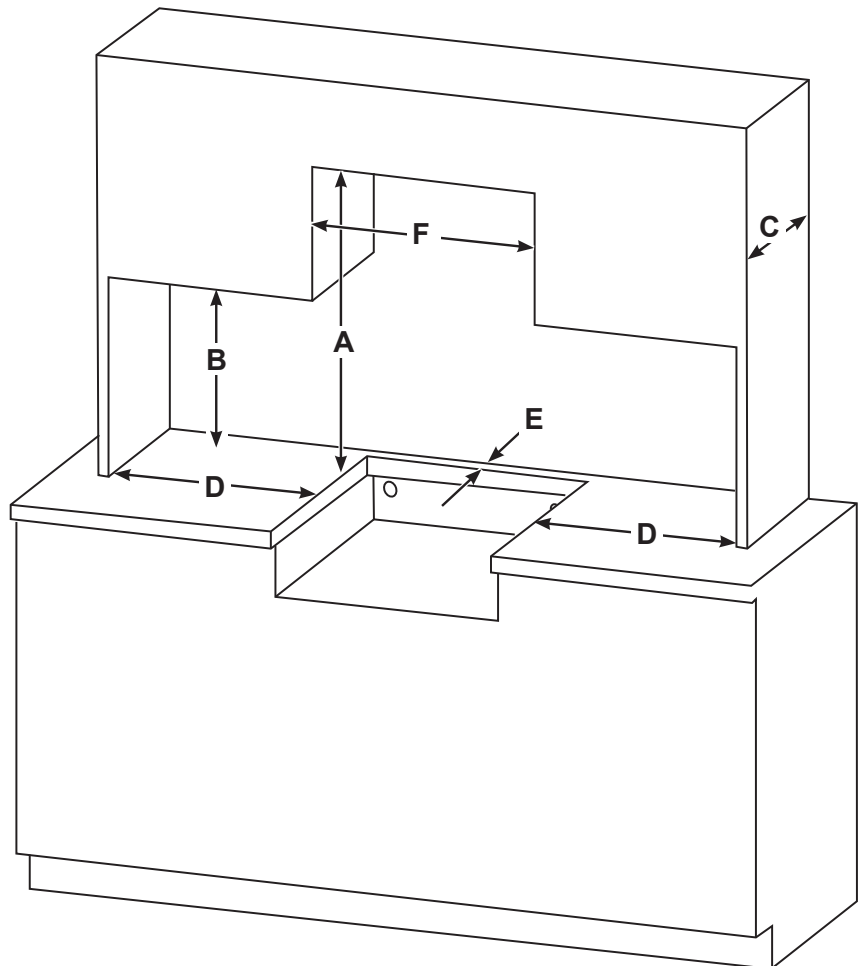

Installation Instructions

GAS AND POWER SUPPLY INSTALLATION LOCATIONS

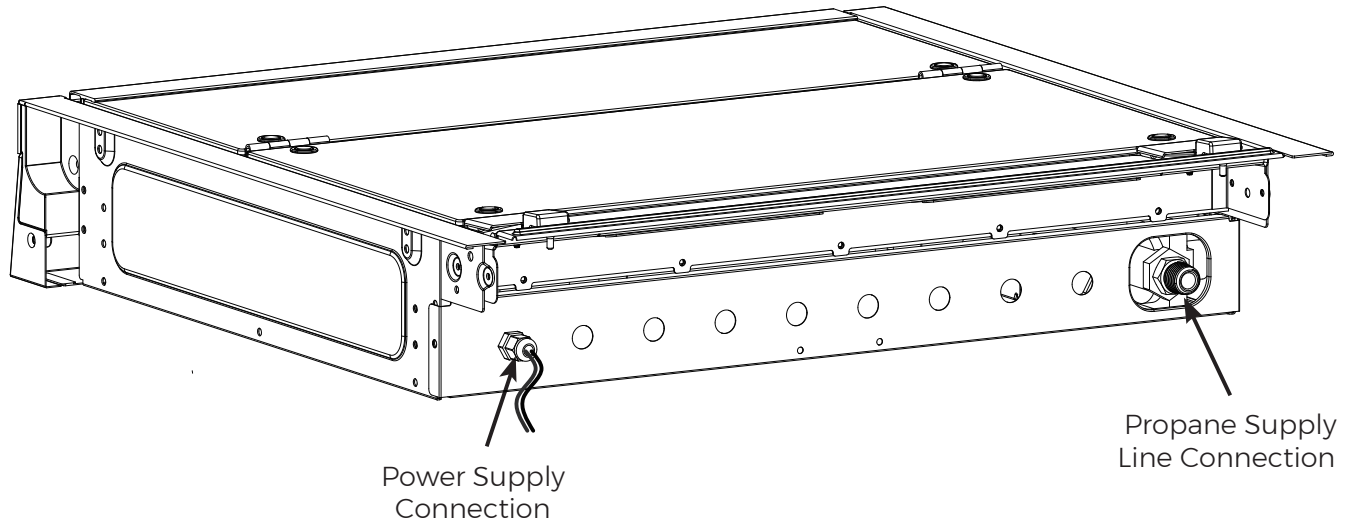

COOKTOP INSTALLATION

NOTE: Prior to performing installation, wear safety gloves and glasses.

Complete the following steps when the cabinet has been prepared according to the dimensions given and the gas line and electrical connections are in place.

1. COOKTOP PREPARATION

- Take your cooktop out of the carton and place on a flat surface. Remove the packing materials.
- Lift up and remove grate from cooktop.

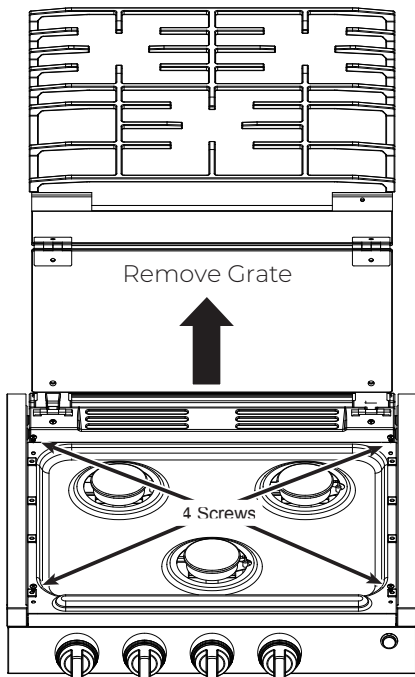

- Remove the 4 screws on the cooktop with a Phillips screwdriver, then lift up on the cooktop to remove.
- Lift the cooktop and set into the cabinet opening. Slide the cook-top back into position.

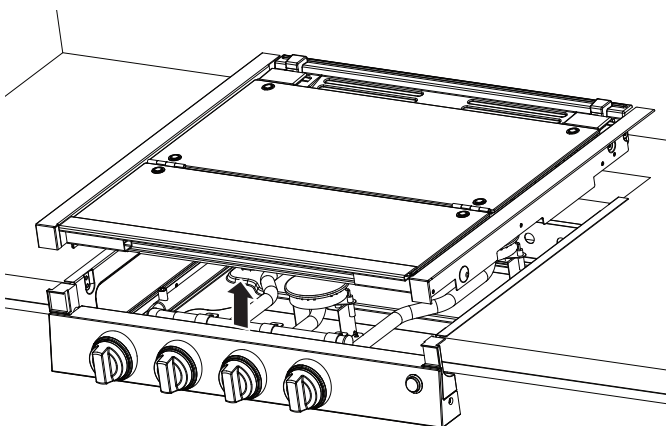

! WARNING **!**

Care should be taken to not damage or modify gas tubing under cooktop. Doing so may result in fire or explosion hazard.

- Attach the cooktop in the cabinet opening by driving four screws into the countertop. Install 2 screws per side using preferred hole options based on countertop construction. If countertop is wooden, start by drilling pilot holes with a 1/8" drill bit. Drive the 4 provided screws into the holes to attach.

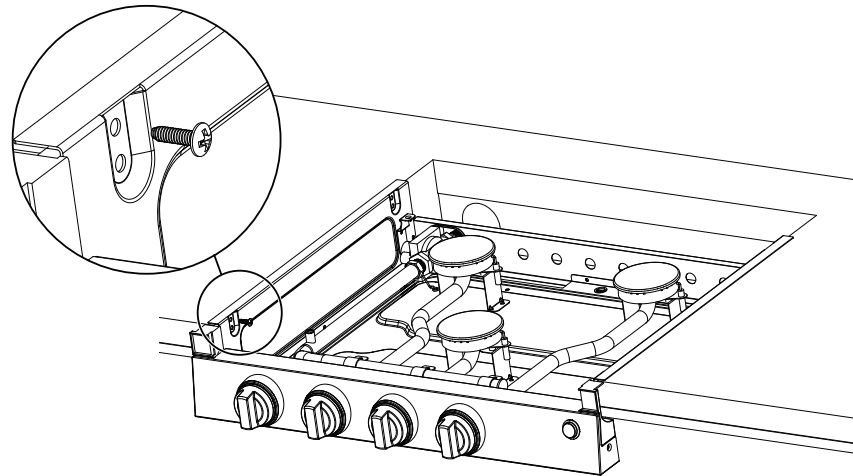

NOTE: There should be an unobstructed vertical gap of .25" under the rangetop to allow for proper combustion and cooling airflow. Do not block this gap.

Installation Instructions

2. GAS SUPPLY

! WARNING

Fire Hazard:

Do not use a flame to check for gas leaks.

! WARNING

Explosion Hazard:

Do not exceed 25 ft-lbs of torque when making gas line connections. Overtightening may crack the pressure regulator resulting in fire or explosion hazard.

! WARNING

Gas leaks may not be detected by smell alone. Gas suppliers recommend you purchase and install an UL approved gas detector. Install and use in accordance with the manufacturer's instructions.

Gas Pressure Regulator

You must use the propane gas pressure regulator supplied with this cooktop. For proper operations the **INLET** pressure to the regulator should be as follows:

Minimum pressure: 11" of Water Column

Maximum pressure: 13.8" of Water Column

Connect a propane supply line with a 3/8" Flare Female connection to the regulator in the upper left rear corner of the cabinet. Tighten the gas line to the regulator using 2 wrenches.

IMPORTANT:

Leave adequate space around the gas supply pipe in case of bend or damage during installation. Make sure the gas supply pipe cannot contact any moving parts after installed. If an individual shut-off valve is installed on the gas supply piping, follow instruction below when a running gas pressure test:

When using pressures of ½ psi (3.5kPa) or less to pressure test the gas supply system, simply isolate the cooktop from the gas supply system by closing the individual shut-off valve.

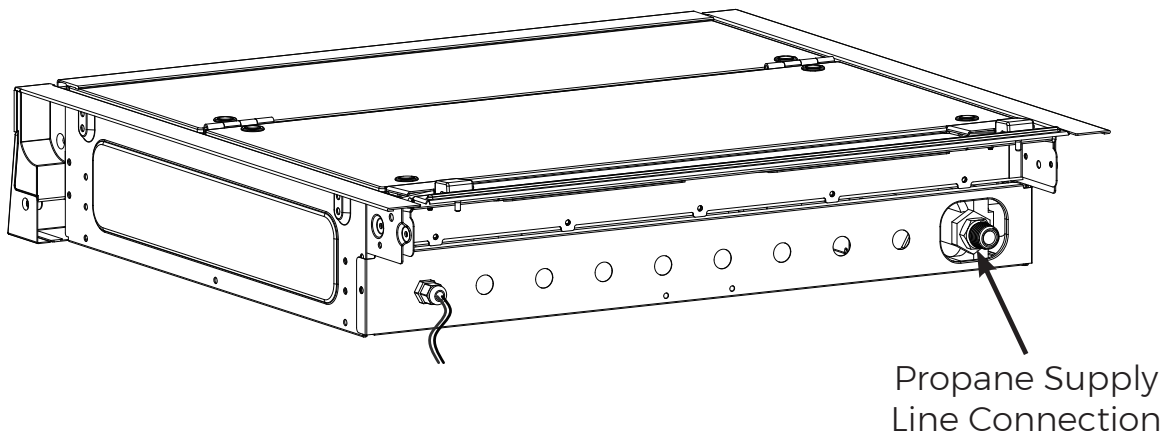

3. PRESSURE CHECK

- Ensure propane gas is turned off to the appliance.
- Remove the screw with the sealing gasket from the pressure test port on the cooktop.
- Using the rubber tube from a pressure check measuring device, slide the rubber tube down over the gas pressure test port. The rubber tube should seal around the pressure test port.
- Turn on the propane gas to the appliance.
- The pressure gauge tester should measure between 10" WC to 13.8" WC which is the **OUTLET** gas pressure range .
- Turn off the propane gas to the appliance.
- Remove the rubber tube of the pressure check measuring device.
- Replace the screw with the gasket removed in the step above. Before replacing the screw, inspect the rubber gasket seal for any signs of damage.
- Hand tighten the screw ensuring not to damage the seal.

NOTE: Ensure the product is gas leak checked after the pressure check test is completed by also testing the pressure check port screw. If any leaks are detected around the pressure test port screw and sealing gasket, a new one can be purchased.

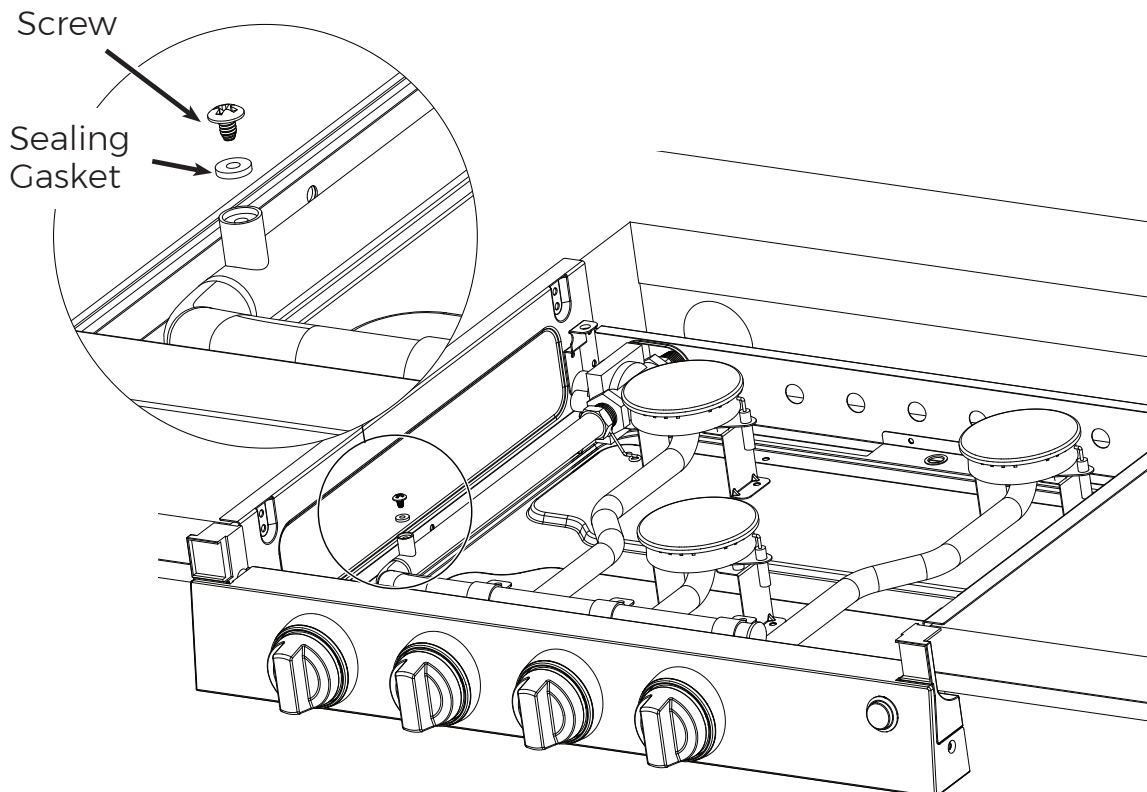

Installation Instructions

4. LEAK CHECK

- Make sure all control knobs are in the OFF position.
- Apply a gas leak detection liquid to the connections. Any gas leaks will be indicated by bubbles.
- If a gas leak is detected, tighten the loose joint, or replace the faulty part with a replacement part recommended by a authorized retailer.

5. ELECTRICAL CONNECTION

The power supply wires are located at the top left corner of the rear of the appliance. Connect a positive 12V power supply wire to the appliance black 12V wire and a negative 12V power supply wire to the appliance white 12V wire. Maximum current draw is less than 1 amp.

NOTE: Ensure to connect the wires with the correct polarity. Black is "+" and White is "-". Ensure electrical connections are properly secured. Ensure electrical supply lines are disconnected, or power removed at the main fuse or circuit breaker panel, before servicing the appliance.

! CAUTION !

PRODUCT DAMAGE HAZARD

- Connect to 12V DC service only.
- Connect only to protected circuit fused for not more than 15 Amps.

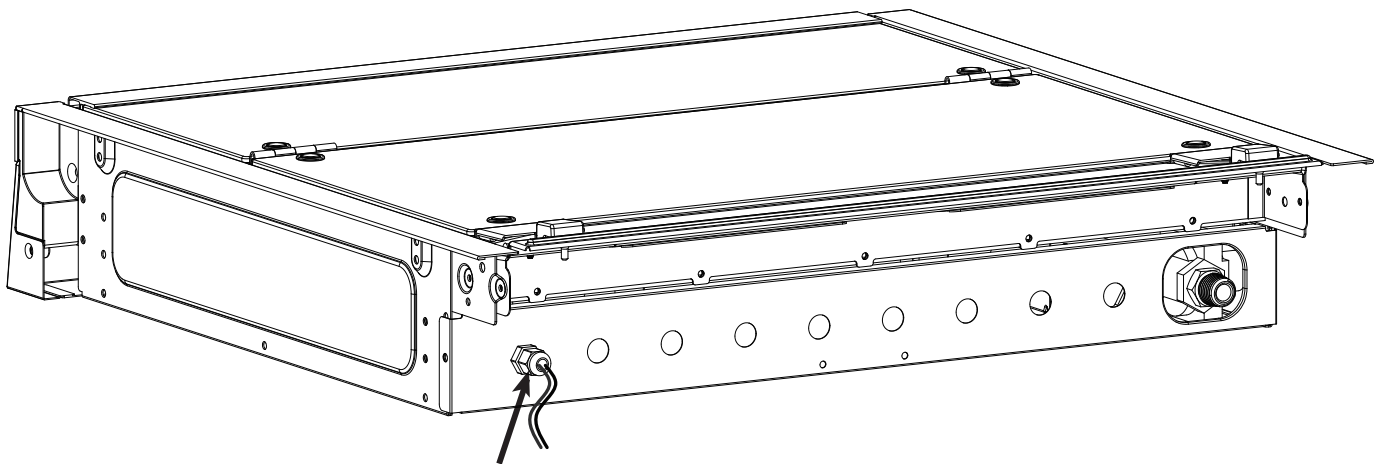

Power Supply
Connection

6. REPLACE COOKTOP

Place the cooktop back into position and attach with the 4 screws, removed in Step 1, using a Phillips screwdriver.

7. TEST COOKTOP BURNERS

- Push and turn the appropriate burner control knob counterclockwise to the HI position.

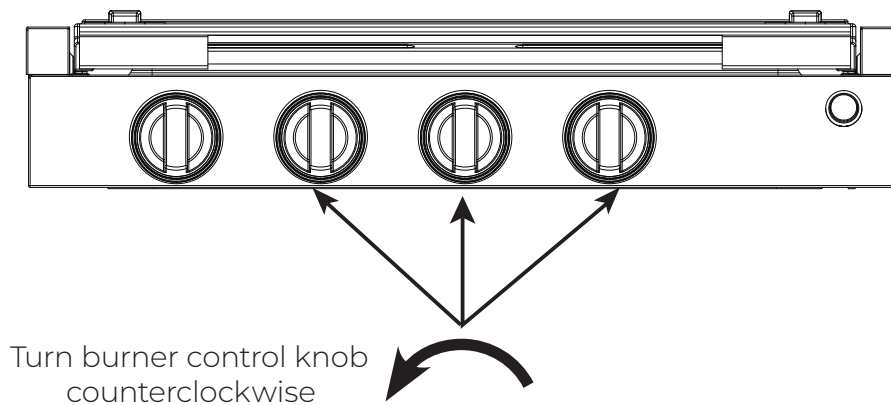

- Turn the ignition knob clockwise continuously until the burner is lit. If air is in the supply line, it may take up to a minute for the air to purge and the burner to light.

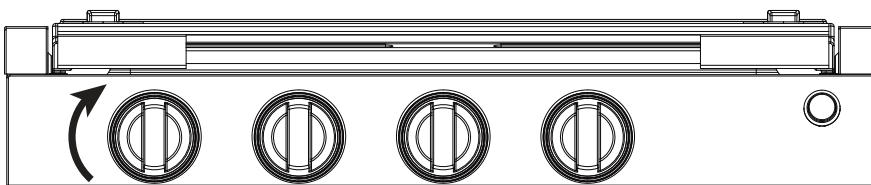

- The flame may burn yellow for a few seconds, then it should turn blue. If the burner continues to burn mostly or completely yellow, see “Troubleshooting” or contact a qualified service technician.
- Rotate the burner control knob to LO. Make sure that the flame completely surrounds the burner. There should be a flame at the burner ports and no air gap between the flame and the burner. If the burner does not meet this criteria, see “Troubleshooting” or contact a qualified service technician.
- Repeat these steps to test each burner.

Installation Instructions

8. FLAME QUALITY

The burner flames for the cooktop burners should be blue with yellow tips. Long, bright yellow flames are not normal. Normal flames may show signs of an orange tint when well heated or signs of flickering orange due to particles in the gas or air.

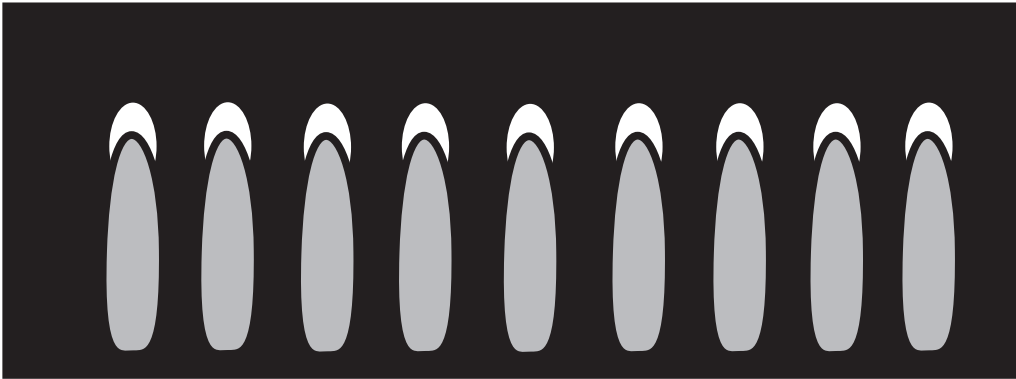

Operating Instructions

COOKTOP

Be sure all controls are off and all surfaces are cool before cleaning any part of the cooktop.

CONTROL KNOBS

The control knobs may be removed for easier cleaning. Make sure the knobs are in the OFF positions and pull them straight off the stems for cleaning. The knobs can be washed with soap and water. Make sure the insides of the knobs are dry before replacing. Replace the knobs in the OFF position to ensure proper placement.

PAINTED COOKTOP TRIM

Clean cooktop trim with soap and water or a vinegar and water solution. Do not use commercial oven cleaners, cleaning powders, steel wool or harsh abrasives on any painted surface.

STAINLESS STEEL SURFACES

Do not use a steel wool pad; it will scratch the surface. To clean the stainless steel surface, use warm sudsy water or a stainless steel cleaner or polish. Always wipe the surface in the direction of the grain. Follow the cleaner instructions for cleaning the stainless steel surface. Cleaners with oxalic acid such as Bar Keepers Friend Soft Cleanser will remove surface rust, tarnish, and small blemishes. Use only a liquid cleanser free of grit and rub in the direction of the brush lines with a damp, soft sponge.

Operating Instructions

COOKTOP

Before lighting, confirm all control knobs are in the OFF position. Make sure the main gas tank valve is open.

- Do not operate the burner for an extended period of time without cookware on the grate. The finish on the grate may discolor or chip without cookware to absorb the heat.
- Cookware should be positioned over the grates and not overhanging the side trim or countertop.
- Be sure the burners and grates are cool before you place your hand, a pot holder or cleaning materials on them.

Lighting the Cooktop

WARNING

Burners should be operated only when covered by cookware. Burner flames not covered by cookware present a risk of fire or clothing ignition. Never let flames extend beyond the sides of the cookware. Failure to comply may result in serious injury.

1. Lift at the front to open the glass cover and fold back. Push and turn the burner control knob counterclockwise to the HI position.

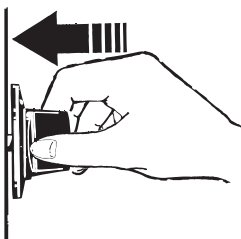

Push the control knob in and turn it to the HI position.

2. Turn the ignition knob clockwise continuously until the burner is lit.

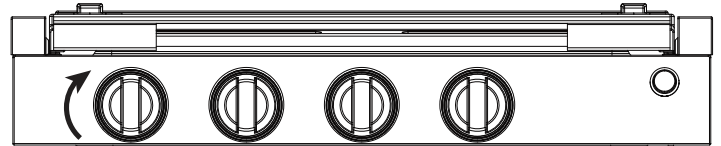

3. Rotate the burner control knob to adjust the flame level.
4. Repeat steps 1-3 to light the other burner(s) as needed.

If a burner does not ignite within 5 seconds, immediately turn the control knob clockwise to the OFF position. Wait at least 5 minutes and repeat the igniting procedure. If ignition still does not occur, use a gas lighter or a match to light the burner. Refer to section "Lighting the Cooktop Manually".

Selecting a Flame Size

Watch the flame, not the knob, as you adjust heat. When rapid heating is desired, the flame size should match the size of the cookware you are using. Flames larger than the bottom of the cookware will not heat faster and may be hazardous.



These flames are too large for the pot

Lighting the Cooktop Manually

If a cooktop burner fails to ignite, you may light the burner manually by following the steps below:

1. Push and turn the burner control knob counterclockwise to the HI position.

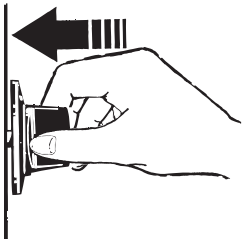

Push the control knob in and turn it to the HI position.

2. Immediately strike and place a burning long wooden match or a gas lighter near the burner to light.
3. Rotate the burner control knob to adjust the flame level.
4. Repeat steps 1-3 to light the other burner(s) as needed.

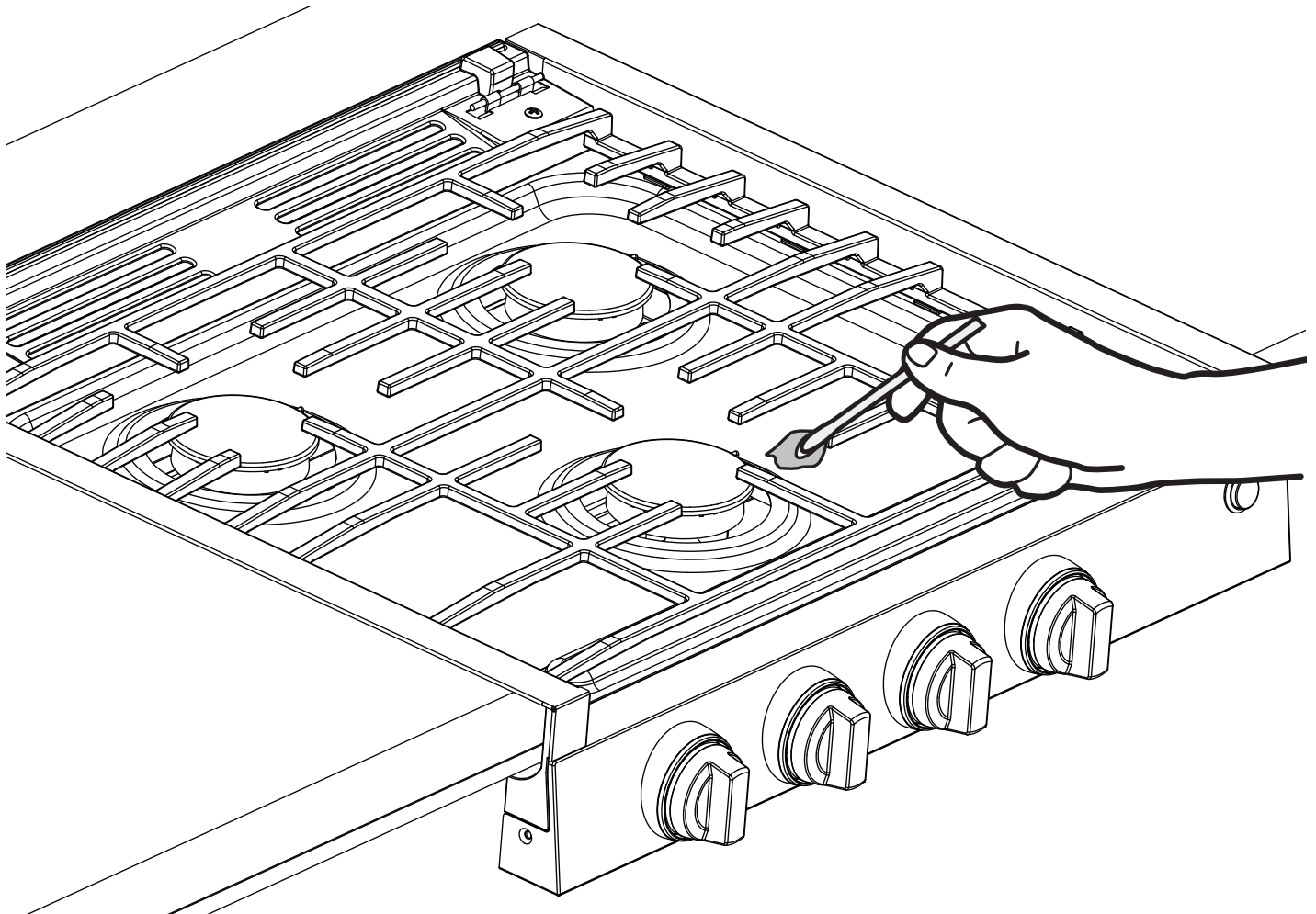

Operating Instructions

If the Flame Goes Out

Immediately turn the control knob to OFF position. Wait at least 5 minutes and light the burner again.

- Be sure the burners and grates are cool before you place your hand, a pot holder or cleaning materials on the cooktop.

Size cookware appropriately to the flames. Cover your cookware with a lid to bring liquids to a boil faster.

3-burner Model: The rear burners are intended for general cooking and simmering. Use the front burner for larger cookware and faster boiling.

Turning Off the Cooktop

To turn the cooktop burners off, rotate the control knobs clockwise to the OFF position. Do not touch or place any objects on the grates until the cooktop has cooled.

Cooktop Burner Usage

- Do not operate the burner for an extended time without cookware on the grate. The finish on the grate may discolor or chip without cookware to absorb the heat.
- Do not attempt to disassemble any burner while another burner is on. Damage to the product may occur.

Cooktop Grate Orientation

The proper install orientation for the grate is as shown. The grate for the 3-burner model has a front and back and must be placed correctly per the image.

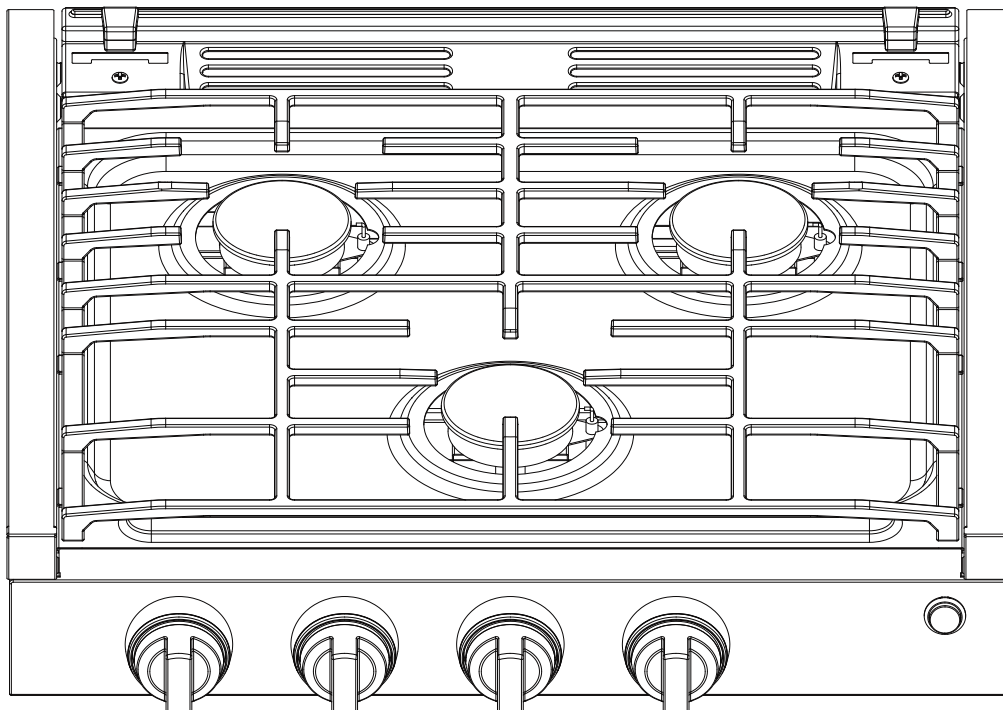

CONTROL KNOB LIGHTS

Press the **Light** button on the control panel to turn on/off the control knob lights. All lights turn on and off together.

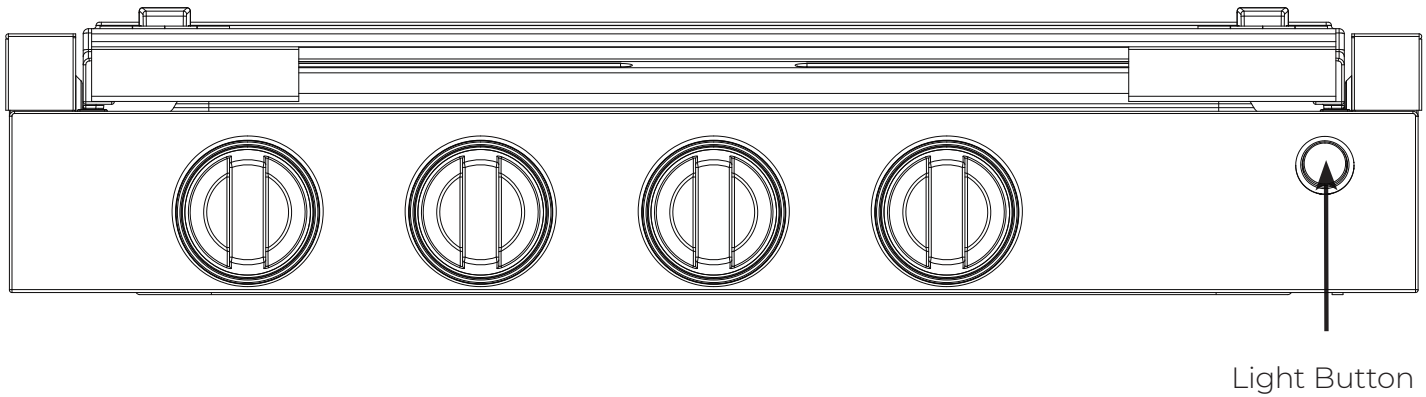

COOKTOP VENTS

Never block the vents (air openings) of the cooktop. They provide the air for the inlet and outlet that are necessary for the cooktop to keep cool and operate properly with correct combustion. Never cover the opening with aluminum foil or any other material. Vents are located along the rear, front, and bottom of the cooktop.

Care & Maintenance

COOKTOP SURFACES

Be sure all controls are off and all surfaces are cool before cleaning any part of the cooktop.

Porcelain Enamel Cooktop

Do not use oven cleaners, abrasive cleansers, strong liquid cleansers, steel wool, plastic scouring pads, or cleaning powders on the cooktop surface. Clean with a mild soap and water or a 50/50 solution of vinegar and water. Rinse with clean water and dry with a soft cloth. When cleaning surfaces, make sure that they are at room temperature. Spillage of marinades, fruit juices, tomato sauces and basting liquids containing acids may cause discoloration and should be wiped up as soon as hot surfaces cool, then clean and rinse. Use caution to not spill water into cooktop openings.

Removing the Cooktop for Cleaning in Case of Spillage

WARNING

Care should be taken to not damage or modify gas tubing and wiring under cooktop. Doing so may result in fire or explosion hazard.

1. Disconnect power at the main fuse or circuit breaker panel before removing cooktop.
2. Lift up and remove grate from cooktop.

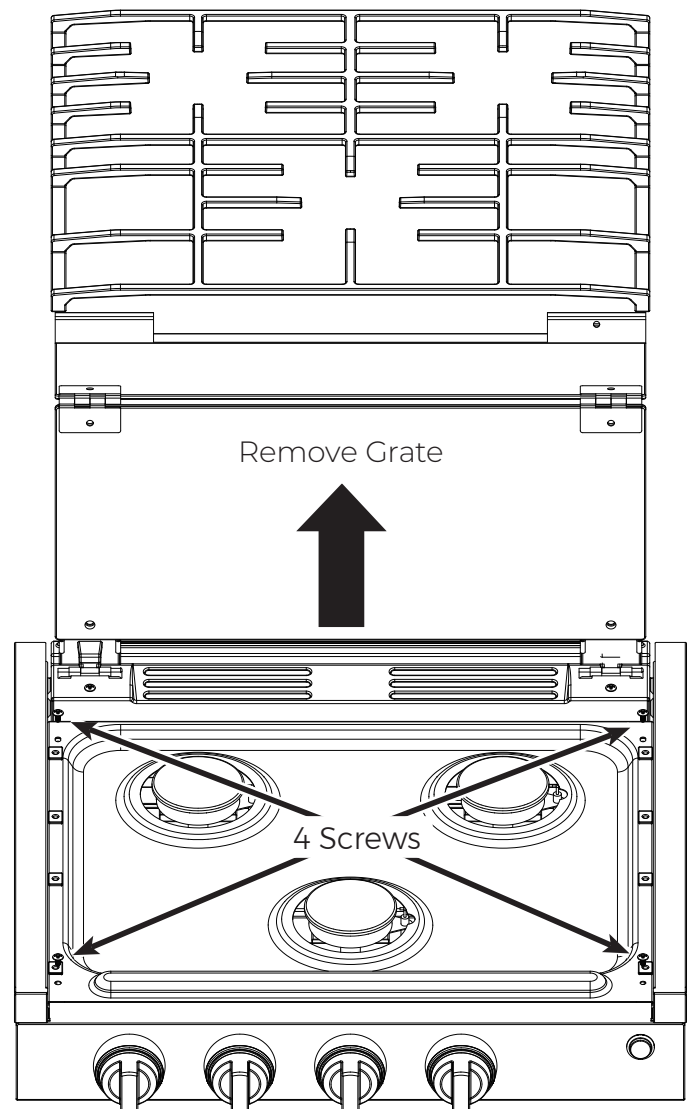

- Remove the 4 screws on the cooktop with a Phillips screwdriver, then lift up on the cooktop to remove.

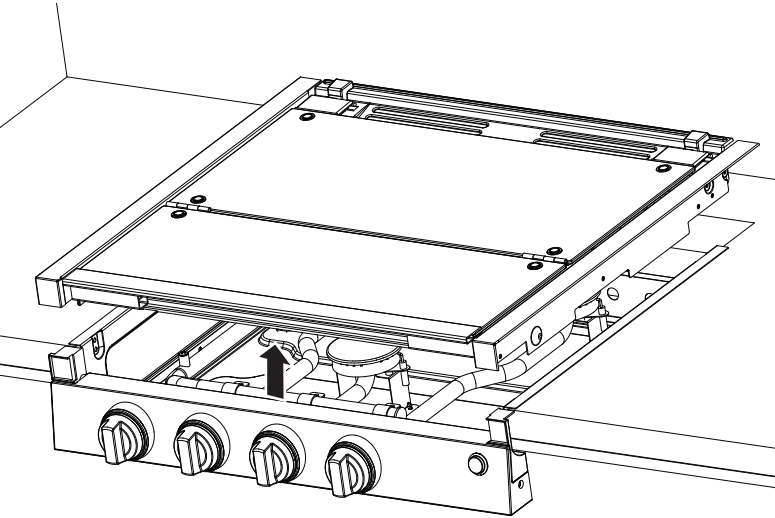

- Clean with a mild soap and water solution with a damp cloth. Rinse with clean water and dry with soft cloth.
- Place the cooktop back into position and attach with the 4 screws using a Phillips screwdriver.

Burner Caps

Wipe burner caps with hot, soapy water and rinse with clean water. You may scour with a plastic scouring pad to remove burned-on food particles.

Burner Heads

Wipe the burner heads routinely, especially after bad spillovers which could clog the burner openings. Wipe with hot, soapy water. Rinse with clean water. For more stubborn stains, use a brush with plastic bristles.

NOTE: Do not use steel wool or scouring pads to clean the burner parts as these may clog the openings. The ports in the burner heads must be kept clean at all times for an even, unhampered flame. Clogged or dirty burner ports or electrodes will not allow the burner to operate properly.

Burner Grates

Grates should be washed in hot, soapy water and rinsed with clean water. To soften burned-on food, place grates in a solution containing $\frac{1}{4}$ -cup of household ammonia for several hours. Afterward, scrub grates with a plastic scouring pad soaked in hot, soapy water. Rinse well and dry. DO NOT use bleach or rust removers on the rangetop or burner grates.

Troubleshooting Guide

Problem	Possible Cause/Solution
Surface burners do not light or do not light fully.	<ul style="list-style-type: none">• Ensure all gas supply valves and propane tank valve are opened.• Ensure knob is pressed and set to the HI position while the ignition knob is turned.• Gas pressure is either too low or too high.• Burner ports or igniter are dirty. Refer to “Burner Heads” in the Care and Cleaning section• Moisture is present on the burner. With burner off and cool, dry burner thoroughly.

Problem	Possible Cause/Solution
<p>Flames are completely or mostly yellow or orange.</p>	<ul style="list-style-type: none"> • Normal flames may show signs of an orange tint when well heated or signs of flickering orange due to dust particles in the gas or air. • Gas pressure is too low. • Burner ports are dirty. Refer to “Burner Heads” in the Care and Cleaning section.
<p>Knob backlighting does not turn on when light button is pressed.</p>	<ul style="list-style-type: none"> • Ensure unit is connected to 12VDC. See “Electrical Connection” in the Installation Instructions. • LED board or switch needs to be replaced.

Product Registration

Product Registration Has Benefits :

Thank you for purchasing your new CONTOURE product!

By completing product registration you are protecting your new investment and obtaining important warranty service information unique to your product.

Registration also allows you to confirm ownership of your product by using registration as an official method of proof of purchase.

When registering your product you can choose to become a member of the CONTOURE team to receive exciting new product notifications, product use tips, unique product features and the latests updates and downloads about CONTOURE products and services.

Register your CONTOURE Product:

We recommend that you visit our website, **www.CONTOUREUSA.com** for a fast, efficient way to register your product online.

If you need help registering your product, or do not have access to the internet, a Customer Service Representative will assist you.

You may contact our Consumer Service Center toll-free at 1-888-656-9317.

Please maintain your original proof of purchase for product registration and warranty service.

Product Warranty

This warranty is available to consumers only. You are a consumer if you own a CONTOURE product that was purchased at a retail store for personal, family or household use. Except as otherwise required under applicable law, this warranty is not available to retailers or other commercial purchasers or owners.

Warranty registration is not mandatory, but doing so will help us to service you more quickly if you need to present a warranty claim or notify you if there is a product recall. Please go online to submit your product registration form. Return of product registration does not eliminate the need for the consumer to maintain the original proof of purchase in order to obtain the warranty benefits. In the event that you do not have proof of purchase date, the purchase date for warranty purposes will be the date of manufacture.

NQP warrants CONTOURE Products ("product") to be free of all defects in material and workmanship for the applicable period specified below commencing from the date of original purchase. This warranty extends to the original buyer only.

Ninety (90) Day Full Warranty Parts & Labor:

Within ninety (90) days from the date of original purchase, NQP/CONTOURE in its sole discretion, will either repair or replace, free of charge, any part proving defective in material or workmanship.

All warranty repairs and service must be performed at a NQP/CONTOURE location of service by an authorized NQP/CONTOURE technician. All expenses related to replacing or repairing a defective part under this ninety (90) day warranty shall be assumed by NQP/CONTOURE except the cost of transporting the

product to and from NQP/CONTOURE, which shall be assumed by the buyer. If the product is replaced, the replacement will be with a product that is identical or equivalent to the warranted product. If the product cannot be repaired or replaced, NQP/CONTOURE will issue a refund to the buyer for the original purchase price less that amount directly attributable to use by the buyer.

Disclaimer of implied warranties; limitation of remedies:

Customer's sole and exclusive remedy under this limited warranty shall be product repair or replacement as provided herein. Claims based on implied warranties, including warranties of merchantability or fitness for a particular purpose, are limited to one year or the shortest period allowed by law, but not less than one year. NQP/CONTOURE shall not be liable for consequential or incidental damages such as property damage and incidental expenses resulting from any breach of this written limited warranty or any implied warranty. Some states and provinces do not allow the exclusion or limitation of incidental or consequential damage or limitations on the duration of implied warranties, so these limitations or exclusions may not apply to you. This written warranty gives you specific legal rights. You may also have other rights that vary from state to state.

One (1) Year Limited Warranty:

After the expiration of the ninety (90) day warranty, and within one (1) year from the date of original purchase, NQP/CONTOURE NQP will replace any part proving defective in material or workmanship with a product that is identical or equivalent to the warranted part. The buyer shall assume the cost of transporting the

Product Warranty

defective product to and from NQP/CONTOURE and will assume the cost of labor associated with repair.

How to Obtain Warranty Service:

Upon discovery of any defect, malfunction, or nonconformity in the warranty-covered product, the buyer should visit www.contoureausa.com and submit a warranty claim online.

For any questions regarding your warranty you may also email us at warranty@contoureausa.com

Notice to Buyer:

This warranty gives the buyer specific legal rights, and the buyer may also have other rights, which vary from state to state. You have the right to bring any action at law or equity to resolve disputes concerning or to enforce the provisions of this warranty. Every implied warranty, including any statutory warranty or condition of merchantability or fitness for a particular purpose, is disclaimed except to the extent prohibited by law, in which case such warranty or condition is limited to the duration and extent of this written warranty.

For added protection and secure handling of any CONTOURE product that is being returned, we recommend that you use a traceable, insured delivery service. NQP/CONTOURE cannot be held responsible for in-transit damage or for packages that are not delivered to us. Lost and/or damaged products are NOT covered under warranty. Please be sure to include your return address, daytime phone number, description of the product defect, product model number (located on the product), original date of purchase and any additional pertinent

information pertaining to the product's return.

Warranty Exclusions:

This warranty does not apply to any costs, repairs or services for the following:

- Products with original serial numbers that have been removed, altered or cannot be readily determined or products purchased "as-is."
- Product that has been transferred from its original owner to another party or removed outside of the USA or Canada.
- Products used in commercial setting(s).
- Service calls to correct the installation of the warranty-covered products, to explain the usage of the product to the buyer, or to reset or replace home circuit breakers or fuses.
- Service calls which do not involve malfunction or defects in materials or workmanship, or for appliances not in ordinary household use or used other than in accordance with the provided instructions.
- Repairs necessitated by use other than normal home use / Products used in commercial settings.
- Damage resulting from misuse, abuse, accidents, alterations, improper installation, fire, flood acts of God or damage caused by the shipping of the product by the buyer to NQP.
- Corrective work necessitated by repairs made by anyone other than a NQP authorized service technician / Rust on the interior or exterior of the unit.
- Costs incurred for disposing of the product at locations other than a NQP facility.

- Expenses for making the appliance accessible for servicing, such as removal of trim, cupboards, shelves, etc. which are not a part of the appliance when it is shipped from the factory.
- Damages to the finish of appliance or home incurred during installation, including but not limited to floors, cabinets, walls, etc.
- Damages caused by: services performed by unauthorized service companies; use of parts other than genuine CONTOURE parts or parts obtained from persons other than authorized service companies; or external causes such as abuse, misuse, inadequate power supply, accidents, fires or acts of God.
- Labor costs after ninety (90) days from your original date of purchase incurred for product repair or replacement as provided herein for carry-in appliances.

This Warranty Only Applies in the USA and Canada:

In the United States and Canada, your appliance is warranted by NQP/CONTOURE. NQP/CONTOURE authorizes no person to change or add any obligations under this warranty. Obligations for service and parts under this warranty must be performed by NQP/CONTOURE or an authorized service company.

California Residents Only:

California law provides that for In-Warranty Service, California residents have the option of returning a nonconforming product.

(1) to the store where it was purchased or (2) to another retail store which sells CONTOURE products of the same type. The retail store shall then, at its discretion, either repair the product,

refer the consumer to an independent repair facility, replace the product, or refund the purchase price less the amount directly attributable to the consumer’s prior usage of the product. If the above two options do not result in the appropriate relief to the consumer, the consumer may then take the product to an independent repair facility if service or repair can be economically accomplished.

NQP/CONTOURE and not the consumer will be responsible for the reasonable cost of such service, repair, replacement, or refund for nonconforming products under warranty.

California residents may also, according to their preference, return nonconforming products directly to NQP for repair, or if necessary, replacement, by calling our Consumer Service Center toll-free at 1-888-656-9317 or sending us an email, warranty@CONTOUREv.com

NQP/CONTOURE will be responsible for the cost of the repair, replacement, and return shipping and handling for such products under warranty.

Copyright:

CONTOURE is a trademark of National Quality Products, LLC and its affiliated companies.

Registered in some countries.

Distributed by National Quality Products, LLC.

©2023 National Quality Products, LLC. All rights reserved.

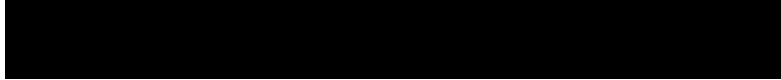

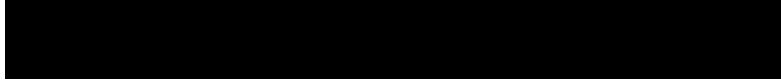

CONTOURE[®]
SPACE SAVER APPLIANCES

VISIT **WWW.CONTOUREUSA.COM** FOR MORE
